



SOLAR STIK®

# OPERATOR AND MAINTENANCE MANUAL FOR THE 24VDC LI EXPANDER PAK 1300

P/N 21-0202316



DISTRIBUTION STATEMENT A. Approved for public release; distribution is unlimited.

Version 1.0

Updated: 20210413

# Contents

## GENERAL INFORMATION, PRINCIPLES OF OPERATION, AND EQUIPMENT DESCRIPTION

<b>Energy Storage Modules - An Introduction</b> . . . . .	<b>4</b>
<b>Important Product Safety Information and Instructions</b> . . . . .	<b>5</b>
Safety Information Labels . . . . .	5
Limitations on Liability. . . . .	5
Fire Hazard . . . . .	6
Recommended Fire Extinguisher . . . . .	6
Electric Shock Hazard. . . . .	7
<b>Environmental and Handling Precautions</b> . . . . .	<b>8</b>
Water . . . . .	8
Impact . . . . .	8
Dust . . . . .	8
Heat . . . . .	8

## PRINCIPLES OF OPERATION – THE EXPANDER PAK

Advanced Battery Management System (BMS). . . . .	9
The Inter-Connect System . . . . .	10
24VDC Linear Inter-Connect Cable . . . . .	11
Optimizing the Battery Configuration . . . . .	12
Determining Proper Battery Capacity for a System. . . . .	12
Scaling Methods. . . . .	13
Keys to Expander Pak Performance . . . . .	14

## EQUIPMENT DESCRIPTION

External Features . . . . .	15
24VDC Li Expander Pak 1300 Linear Inter-Connect Cable . . . . .	15
Data Plate (D-Plate) . . . . .	16

## OPERATOR INSTRUCTIONS

<b>Connect Expander Paks to Inter-Connect Strip.</b> . . . .	<b>17</b>
<b>Connect Expander Paks to Power Management</b> . . . . .	<b>18</b>
<b>Alternative Methods of Recharging the Expander Pak.</b> . . . .	<b>18</b>
Recharging Voltage . . . . .	18
Correct Polarity . . . . .	18

## MAINTENANCE INSTRUCTIONS

<b>Expander Pak Storage.</b> . . . .	<b>19</b>
<b>In-storage Preventive Maintenance Checks and Services.</b> . . . .	<b>20</b>
<b>Li Expander Pak Transport</b> . . . . .	<b>21</b>
Air . . . . .	21
Ground. . . . .	21
<b>Disposal – LiFePO<sub>4</sub> Battery</b> . . . . .	<b>22</b>
<b>Technical Specifications</b> . . . . .	<b>23</b>
<b>Accessories.</b> . . . .	<b>23</b>

## ADDENDUM – Understanding Li Expander Paks

### ABOUT SOLAR STIK, INC.

<b>Contact</b> . . . . .	<b>29</b>
--------------------------	-----------

## List of Figures

Figure 1. Linear Inter-Connect Plug.....	11
Figure 2. Connecting Li Expander Paks using Inter-Connect Strips and Inter-Connect Cables.....	13
Figure 3. External features of the Expander Pak.....	15
Figure 4. Li Expander Pak 1300 Inter-Connect Cable plugs .....	15
Figure 5. 24VDC Li Expander Pak 1300 D-Plate .....	16
Figure 7. Connecting and stacking multiple Expander Paks.....	17
Figure 6. Connecting Inter-Connect Cable to Expander Pak.....	17
Figure 8. Connecting Expander Paks to Solar Stik power management .....	18
Figure 9. 24VDC Li Battery Maintainer with Inter-Connect Plug .....	18

## List of Tables

Table 1. In-storage Preventive Maintenance Checks and Services .....	20
--	----

## Revision History

Section	Page(s)	Description	Date
		First published	March 2019
All	Most	Update Expander Pak 1300 Images (new large I-Plate)	25March2019
All	Most	Update organization and content	02Oct2019
		Update to photos of 1300 with Tech Port and new Data Plate. Updated specifications.	03June2020

# GENERAL INFORMATION, PRINCIPLES OF OPERATION, AND EQUIPMENT DESCRIPTION

## Energy Storage Modules - An Introduction

Energy Storage Modules (ESMs or “batteries”) serve as the foundation for every Hybrid Power System (HPS). When ESMs are employed in a HPS, they can serve many different functions:

- Backup power for critical loads when the primary power source fails
- Power when periods of “silent” operation are critical
- Use of renewable power generation is desirable
- Less reliance on grid-utility power is desirable (peak shaving)

ESMs are also critical to the operation of the Inter-Connect network. They open the system architecture to allow multiple technologies to operate in concert. When functioning ESMs are congregated within the Inter-Connect Circuit, their collective voltage is what allows the other components within the network to perform their functions.

There is a wide range of energy storage technologies, including small- and large-format lithium iron phosphate ( $\text{LiFePO}_4$ ) and lead-acid (Pb) batteries. ALL batteries are “consumable” parts of the HPS.

While the role ESMs serve can be widely varied, their function is quite simple: ESMs discharge and recharge over time; this is known as “cycling”. Batteries are designed with a finite cycle-life expectancy, and several factors will determine how many cycles a battery can endure before it is depleted including:

- cell chemistry
- operational environments and conditions
- charging and discharging rates
- storage conditions (The chemical reaction in a battery never stops even when it is not actively cycling.)

All of these play roles in cycle-life expectancy, so selecting the best battery chemistry for a particular application is critical.

Formats and chemistries are selected based on the requirements of a particular application, but regardless of the battery type used in an HPS, there are two common attributes of all ESMs:

- Scalable—ESMs are scalable to meet System performance requirements.
- Modular—ESMs can be rotated, serviced, and/or swapped within the Inter-Connect network.

When assembling ESMs into an HPS for a particular application, the following need to be considered:

- Consistency of chemistry
- Consistency of operating voltage
- Proper cycling
- Proper capacity for the intended load / application
- One battery bank (connected together, not disparately)

# Important Product Safety Information and Instructions

This manual contains important safety instructions that must be followed during the installation and operation of this product. Read all instructions and safety information contained in this manual.

Exercise caution when handling or operating equipment. Live power may be present.

## Safety Information Labels

Your safety and the safety of others is very important.

Always read and obey all safety messages.



This is the safety alert symbol. This symbol alerts you to potential hazards that can kill you or hurt you and others. All safety messages will follow the safety alert symbol and the word “DANGER”, “WARNING”, or “CAUTION”. These words are defined as:

**⚠ DANGER** Indicates a hazardous situation which, if not avoided, will result in death or serious injury.

**⚠ WARNING** Indicates a hazardous situation which, if not avoided, could result in death or serious injury.

**⚠ CAUTION** Indicates a hazardous situation which, if not avoided, could result in minor or moderate injury.

All safety messages will tell you what the potential hazard is, how to reduce the chance of injury, and what can happen if the instructions are not followed.

## Limitations on Liability

Since the use of this manual and the conditions or methods of operation, use, and maintenance of this product are beyond the control of Solar Stik, this company does not assume responsibility and expressly disclaims liability for loss, damage, or expense—whether direct, indirect, consequential, or incidental—arising out of or anyway connected with such operation, use, or maintenance.

Due to continuous improvements and product updates, the images shown in this manual may not exactly match the unit purchased.

This equipment **CAN BE USED FOR CONNECTION WITH LIFE SUPPORT SYSTEMS OR OTHER MEDICAL EQUIPMENT** or devices; however, without limiting the generality of the foregoing, Solar Stik makes no representations or warranties regarding the use of the System in connection with life support systems or other medical equipment devices.

## Fire Hazard

### Fire Types

**Class A fire** - Fires in ordinary combustibles such as wood, paper, cloth, trash, and plastics.

**Class B fire** - Fires in flammable liquids such as gasoline, petroleum, oil, and paint.

**Class C fire** - Fires involving energized electrical equipment such as motors, transformers, and appliances. Remove the power source and the class C fire becomes a class A or B fire.

### Recommended Fire Extinguisher

NSN 4210-00-288-7219 Fire Extinguisher, Carbon Dioxide, 10 lb

Carbon dioxide is a liquefied gas, which is highly effective fighting class B and C fires. These extinguishers are ideal for areas where contamination and/or cleanup are a concern, such as data processing centers, labs, and telecommunication rooms.



### Using the Fire Extinguisher

When using the extinguisher on a fire, remember **PASS**:

**P**ull the pin.

**A**im the nozzle or hose at the base of the fire from a safe distance.

**S**queeze the operating lever to discharge the fire extinguishing agent.

**S**weep the nozzle or hose from side to side until the fire is out. Move forward or around the fire as the fire diminishes.

Watch the area for reignition until the cause has been fixed.

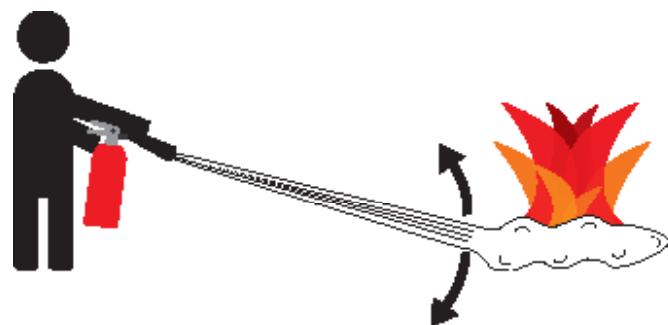

These additional cautionary steps will ensure your safety:

- System components should not be operated in standing water.
- System cables should not be routed through standing water.
- Cable connections should remain dry.
- Unused ports on System components should be covered when not in use to reduce the possibility of water intrusion.

## Electric Shock Hazard

### **⚠ WARNING**

Standing water around the electrical equipment and/or intrusion of water into the System components can increase the risk of electrical shock.

**DON'T LET THIS BE YOU!**



**HIGH VOLTAGE:** System components, photovoltaic (PV) arrays, and generators may produce lethal line voltages. Extreme care should be taken to protect against electrocution. Always work with another person in case an emergency occurs. Disconnect power before performing maintenance. Wear safety glasses whenever working on any part of a System that requires exposure to mechanical or direct electrical contacts.

### **⚠ WARNING**

The Expander Pak is NOT GFCI protected.

# Environmental and Handling Precautions

## Water

Place the Expander Pak 1300 flat on an elevated surface to prevent water intrusion or submersion during outdoor operation and/or storage.

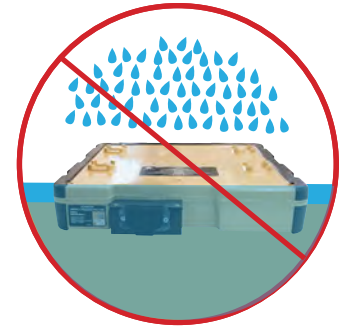

## Impact

The Expander Pak should not be dropped onto hard surfaces at a height greater than one foot when transporting or during operation.



## Dust

As a general rule, minimize exposure to high levels of particulates by exercising common-sense placement.

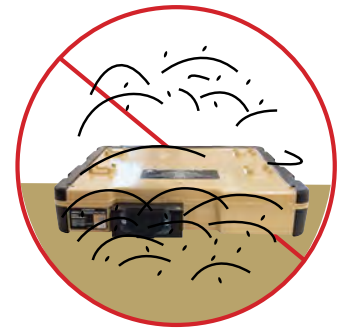
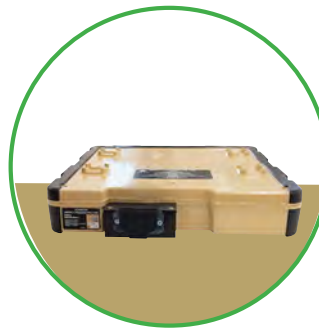

## Heat

Heat and solar loading reduce efficiency and life expectancy. Shade the Expander Pak to prevent the negative effects of heat.





## PRINCIPLES OF OPERATION – THE EXPANDER PAK

The Expander Pak is designed as a modular, scalable energy storage module (ESM) for service in any stand-alone power platform. Insertion of an Expander Pak into a circuit will allow the operator to “expand” the architecture and improve the operating the efficiency of the entire network.

Expander Paks serve as the foundation for all hybrid power systems, allowing the use of renewables and traditional power sources, simultaneously, in the same System.

### The 24VDC Expander Pak 1300:

- 54 Ah (1.3 kWh) of energy storage capacity
- LiFePO<sub>4</sub> cell chemistry
- High energy density—twice that of lead-acid (double the energy for its weight)
- High cycle life > 3000 cycles (@80% depth of discharge)
- Plug & Play connection
- Rapid and deep discharges (can go to near 0% without hurting the cells)
- Rapid recharges
- Internal circuit protections
- Integrated vertical stacking
- 19-inch rack compatible
- One-person lift
- Inert and nonhazardous when 100% discharged
- Ruggedized for extreme conditions
- Designed to MIL-STD-810G; GVT Safety Confirmation for worldwide deployment
- Transportable by land, sea, and cargo air

Adherence to operation and safety protocols will yield optimal performance from the Li Expander Pak for many years. Procedures for operation, preventive care, and maintenance are in this manual.

Please read this manual thoroughly before operating the Li Expander Pak.

## Advanced Battery Management System (BMS)

The 24VDC Li Expander Pak consists of LiFePO<sub>4</sub> cells and an advanced battery management system (BMS) that performs two vital functions:

- The BMS manages the battery functions and promotes healthy cycling at the cells.
- The Protection Circuits protect the cells (and the operator) from dangerous conditions related to cell voltages, temperatures, and current flowing in/out of the battery.

When all of the operating conditions are satisfactory, direct current (DC) can flow in/out of the battery cells (cycling). If the temperature, voltage, or current is outside of the preset limits, then the BMS protection circuits engage and remove the cells from service by disabling the battery at its terminals until proper operating conditions are restored.

## The Inter-Connect System

The HPS is comprised of three (3) distinct types of technologies:

- Energy storage
- Power management
- Power generation

All of the individual components that operate in these categories utilize a unique connection architecture known as the Inter-Connect Circuit.

The Inter-Connect Circuit is the connection framework of the System's DC power network. It uses a simple, polarized, locking connection that is common throughout the architecture. All power management, energy storage, and power generation components are compatible with the Inter-Connect Circuit.

Using a common, polarized connector allows rapid "Plug & Play" scaling of components, adaptation of capabilities within the architecture, technology refreshment, and swapping of components when conditions warrant. It also ensures there is no unsafe way to make connections.

### Circuit Breaker Protections

The Inter-Connect Circuit is protected from overloads and short circuits through a network of circuit breakers strategically placed throughout the circuit. It ensures the potential for a reverse polarity connection within the circuit is minimized. If a problem occurs in a leg of the Inter-Connect Circuit, the affected leg will disconnect from the primary network, leaving the other circuits functioning. If a major failure occurs in the circuit, then the entire network will shut down for System and Operator protection.

### Operate with Voltage

The Inter-Connect Circuit communicates simple battery voltage to all components on the network, allowing them to independently coordinate their respective functions. Battery voltage is used to trigger actions such as Automatic Generator Start/Stop (AGS) function, power distribution timing, and more. Therefore, the proper setup of the Inter-Connect Circuit is critical to properly communicate voltage to all points in the System and to ensure all of the components operate together to provide seamless power to the load.

### Optimize with Data

Data collection for a System occurs through the Inter-Connect network. Power management devices such as Power Hubs and PRO-Verters meter voltage, current and time through the circuit, providing critical real-time data the operator can use to troubleshoot and verify System performance. Data collection enables programming/architectural changes to optimize performance based on evolving conditions.

## 24VDC Linear Inter-Connect Cable

Inter-Connect Cables for use with the Li Expander Pak 1300 have two types of plugs: straight and angled. The straight plug connects to the Expander Pak 1300 to facilitate stacking (Figure 1).

- Polarized connectors
- 200 A maximum current
- 24 VDC connection only
- Mechanically “locks” into place
- Rotate knob clockwise to lock, counterclockwise to release
- Can be repaired or modified in the field

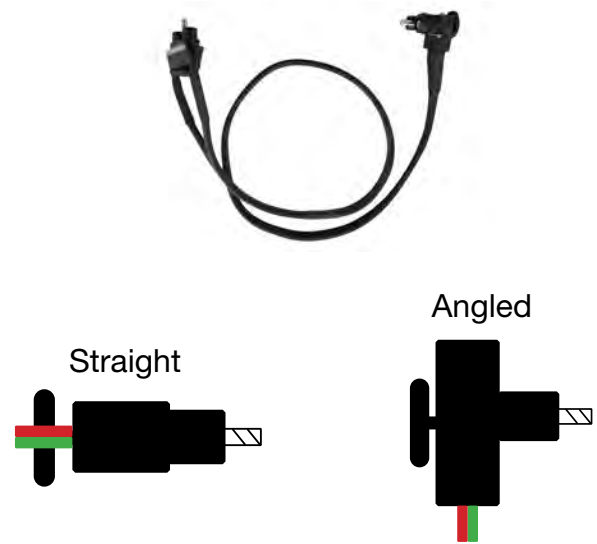

Figure 1. Linear Inter-Connect Plug

## Optimizing the Battery Configuration

The HPS will function most efficiently when proper balance is achieved within the System's architecture (Energy Storage, Power Management, and Power Generation). The foundational component in the Solar Stik System architecture is the battery (Expander Pak, ESM). Generally, the amount of energy storage (battery capacity) required for any System will be directly proportional to the amount of load and power generation that is required for 1-2 battery cycles per day; however, two other system factors may also play a role in determining the necessary capacity:

- Application (External factors such as logistics and operation climate)
- Capabilities (Internal factors such as System composition, including generation, AC/DC power management, distribution, etc.)

Power Management components that are connected to the battery bank must be able to pull and push enough current (amperage) to/from the batteries to support their individual functions. This requires the establishment of a "minimum" capacity for proper system operation.

For example, PRO-Verters can require extremely high current (amperage) from the batteries when AC loads require power from the inverter, but they can also push high current into the battery when it is in charge mode.

Each Expander Pak has a built-in circuit breaker that will limit the amount of current available from the individual batteries. In most System configurations where Expander Paks are used, the combined current limits of the Expander Pak circuit breakers must be greater than the rated demand of the connected power management/distribution equipment.

Connecting an insufficient number of Expander Paks will result in a situation where the following may occur:

- Circuit protections may engage unnecessarily,
- Inaccurate voltage readings may falsely trigger voltage-related functions in the system,
- Battery state of health and overall life expectancy are degraded due to excessive cycling.

Refer to the "Minimum Battery Capacity Recommendations" in the System manuals or on relevant I-Plates to ensure trouble-free operation.

## Determining Proper Battery Capacity for a System

Inherent to the HPS architecture is the ability to "scale" components to meet the System requirements, and a properly scaled battery bank is essential for successful operation of any HPS. Two general guidelines should be followed when scaling Expander Paks for proper capacity:

1. Power generated for a System must be equal to or greater than the total load requirement, so the battery bank must be able to store the requisite power.
2. A properly-sized battery bank will cycle 1–2 times per day.

The total load in a 24-hour period can be used to baseline the energy storage capacity for a System. For example, if the total load requirement over 24 hours is 10 kWh, then the energy storage capacity can usually be scaled to that same metric.

## Scaling Methods

“Plug & Play” architecture allows rapid expansion or contraction of battery capacity when conditions warrant.

Use Inter-Connect Strips and Inter-Connect Cables to create an “bank” of Li Expander Paks (Figure 2).

If a Solar Stik System needs to be downsized, due to either reductions in the load or simply to reallocate energy storage resources to other locations, then Li Expander Paks can be removed from service in accordance with reductions in runtime requirements.

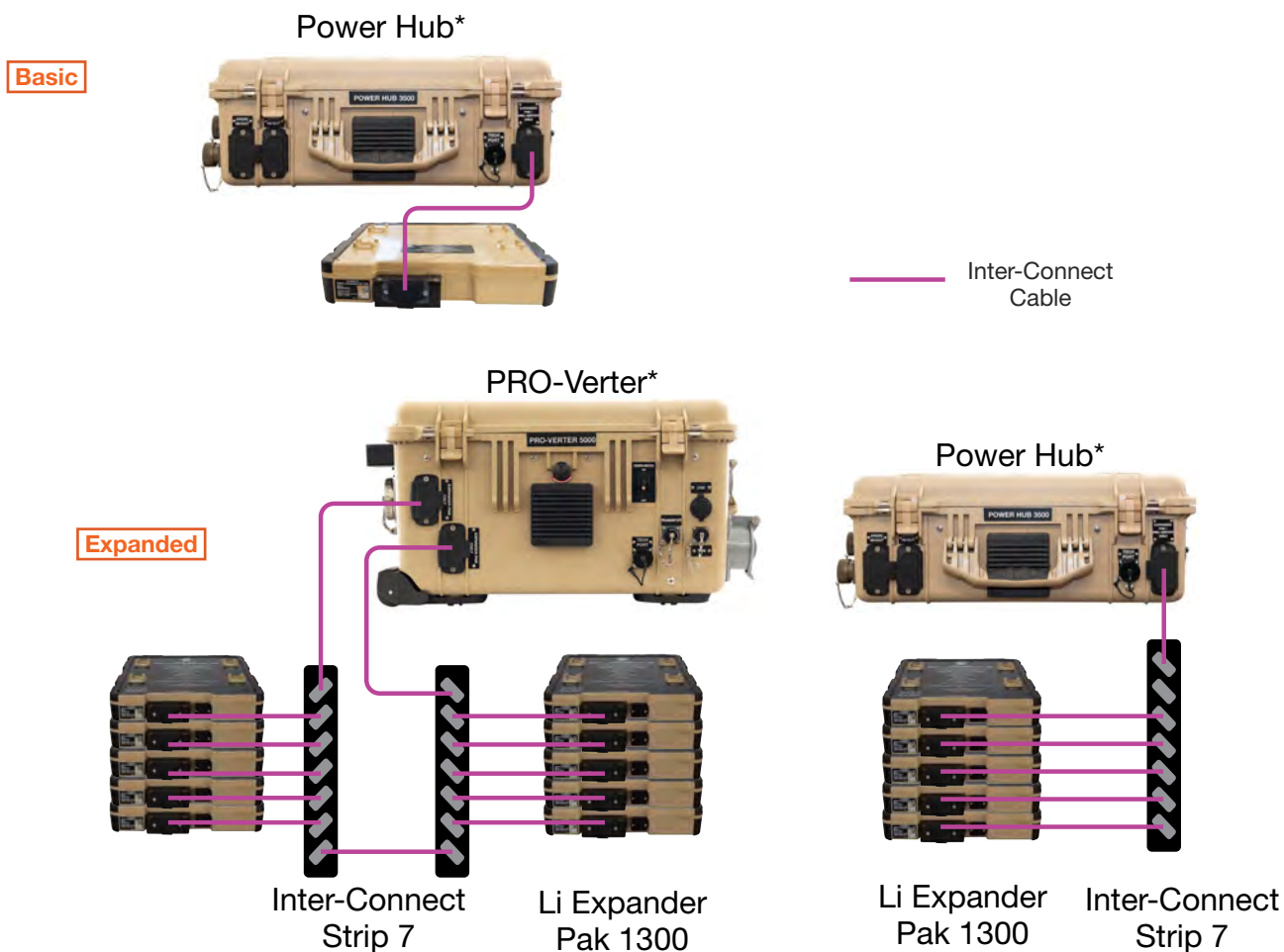

Figure 2. Connecting Li Expander Paks using Inter-Connect Strips and Inter-Connect Cables

\*Solar Stik power management components have minimum battery capacity requirements for operation at their rated capacities. Consult individual component manuals for their respective minimum capacity requirements.

## Keys to Expander Pak Performance

- All Expander Paks should be connected into a single, common bank.
- All Expander Paks comprising a battery bank should be the same chemistry.
- All Expander Paks operating in a bank should be close in health (age, cycles, capacity).
- Follow initialization and calibration steps in System manuals when putting Expander Paks into service in a bank (system).
- Expander Paks prefer to be charged using a PRO-Verter or Power Hub. If any other charging device is used, it must be rated for the Expander Pak's storage capacity, voltage, and current limit (see [Alternative Charging Methods](#)).
- Accurate monitoring reports (current, voltage, SOC, cycles, etc.) of a bank of Expander Paks should be obtained from the system's PRO-Verter or Power Hub. **Note:** Information about individual Expander Paks is not reported by the PRO-Verter or Power Hub.
- **Charge Expander Paks fully before placing them into storage.**
- Follow [In-storage Maintenance Protocols](#)

# EQUIPMENT DESCRIPTION

## External Features

- **Inter-Connect Port:** Point of connection with the system 24 VDC bus, Inter-Connect Circuit
- **Stacking Locks:** Provide stability and alignment for stacked Expander Paks
- **Tech Port:** Contact Solar Stik Technical Support for information.

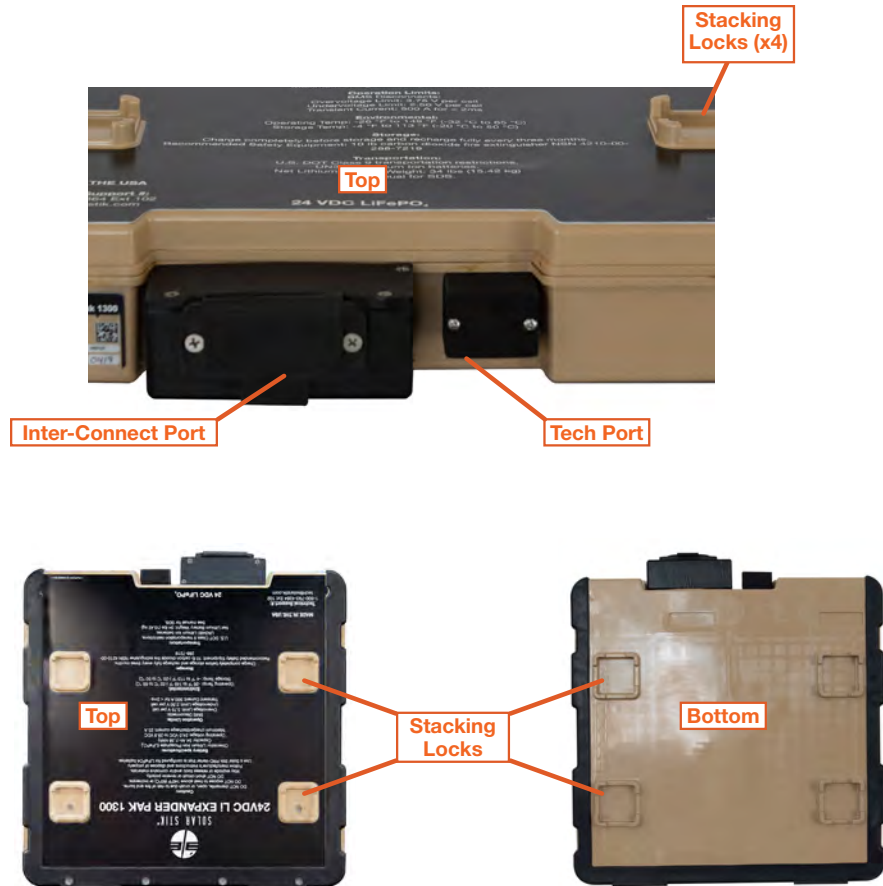

Figure 3. External features of the Expander Pak

## 24VDC Li Expander Pak 1300 Linear Inter-Connect Cable

Inter-Connect Cables for use with the Li Expander Pak 1300 have two types of plugs: linear and angled (Figure 4). The linear plug connects to the Expander Pak 1300 to facilitate stacking (Figure 7).

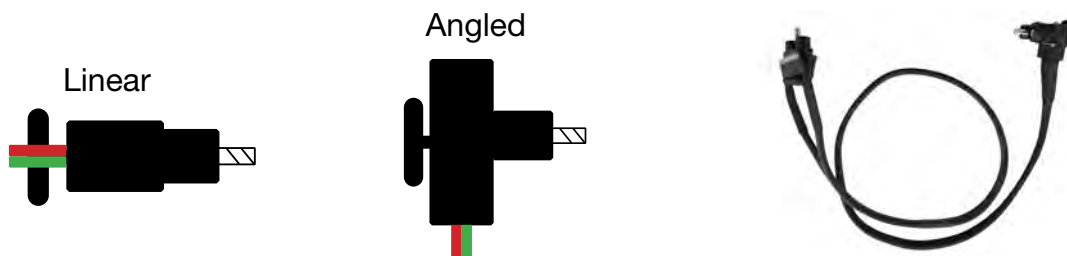

Figure 4. Li Expander Pak 1300 Inter-Connect Cable plugs

## Data Plate (D-Plate)

**24VDC Li EXPANDER PAK 1300**

**Caution:**  
DO NOT dismantle, open, or crush due to risk of fire and burns.  
DO NOT expose to heat above 140°F (60°C) or incinerate.  
DO NOT short circuit or reverse polarity.  
May explode or release toxic and/or corrosive materials.  
Follow manufacturer's instructions and dispose of properly.  
Use a Solar Stik PRO-Verter that is configured for LiFePO<sub>4</sub> batteries.

**Battery specifications:**  
Chemistry: Lithium Iron Phosphate (LiFePO<sub>4</sub>)  
Capacity: 54 Ah (1.38 kWh)  
Operating voltage: 24.0 VDC to 28.8 VDC  
Maximum charge/discharge current: 25 A

**Operation Limits:**  
BMS Disconnects:  
Overvoltage Limit: 3.75 V per cell  
Undervoltage Limit: 2.50 V per cell  
Transient Current: 500 A for < 2ms

**Environmental:**  
Operating Temp: -26 °F to 149 °F (-32 °C to 65 °C)  
Storage Temp: -4 °F to 113 °F (-20 °C to 50 °C)

**Storage:**  
Charge completely before storage and recharge fully every three months.  
Recommended Safety Equipment: 10 lb carbon dioxide fire extinguisher NSN 4210-00-288-7219

**Transportation:**  
U.S. DOT Class 9 transportation restrictions.  
UN3480 Lithium Ion batteries.  
Net Lithium Battery Weight: 34 lbs (15.42 kg)  
See manual for SDS.



**21-0202316**  
**24VDC Li Expander Pak 1300**

**Battery Specifications:**  
Chemistry: LiFePO<sub>4</sub>  
Capacity: 54.0 Ah (1.38 kWh)  
Operating Voltage: 25.6 VDC  
Transport: UN3480 Class 9

REV -

SN: 000101  
DOM: 0419

Figure 5. 24VDC Li Expander Pak 1300 D-Plate



## OPERATOR INSTRUCTIONS

The 24VDC Expander Pak 1300 normal operating voltage ranges from 21.0 VDC to 29.0 VDC. Prior to operating the Expander Pak for the first time, charge it fully. Recharge it with a PRO-Verter, Power Hub, or an external charging source, such as a battery charger, until the battery reaches 100% SOC.

### Connect the Inter-Connect Cable to the Expander Pak

1. Connect the (4 AWG) Inter-Connect Cable linear-plug to the Expander Pak. The plug and socket are polarized (Figure 6A) and can be connected only in the proper orientation.
2. After inserting the plug into the socket (Figure 6B), twist the knob to lock the connection.

**Note:** The red wire cover denotes the positive (+) terminal, and green (or black) denotes the negative (-) terminal.

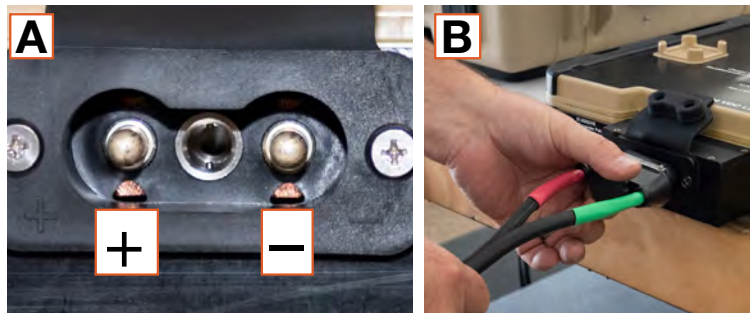

Figure 6. Connecting Inter-Connect Cable to Expander Pak

### Connect Expander Paks to Inter-Connect Strip

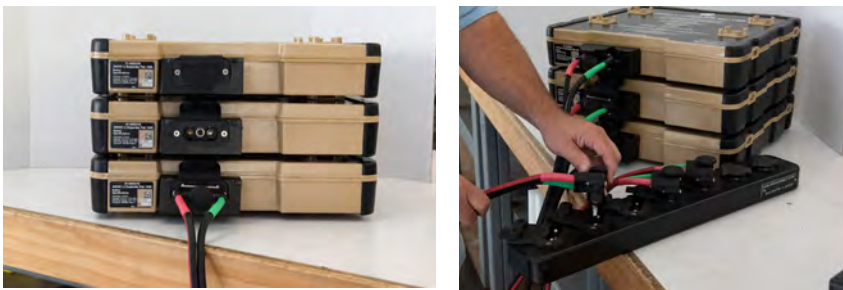
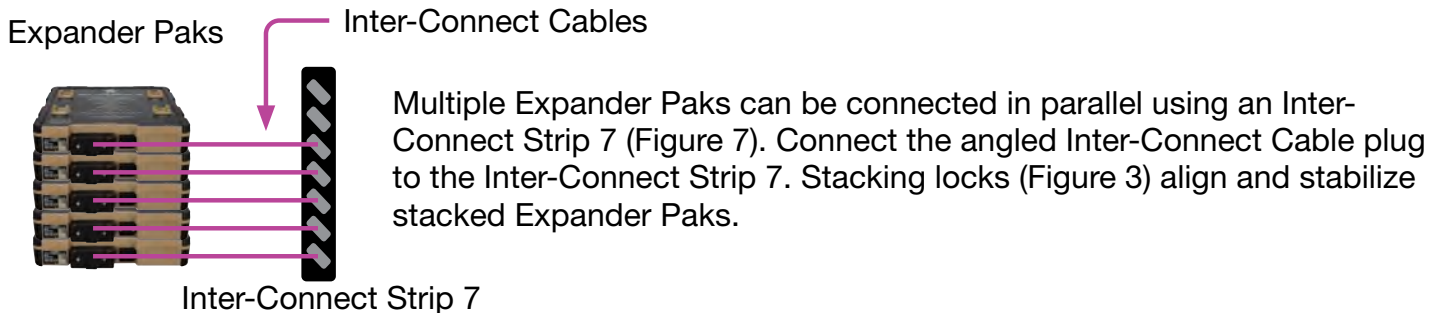

Figure 7. Connecting and stacking multiple Expander Paks

## Connect Expander Paks to Power Management

Expander Pak–specific ports on Solar Stik power management components are labeled. Individual Expander Paks or a bank of Expander Paks can be connected to these ports. Expander Pak–specific ports are metered and can be used to measure the current flowing into and out of the bank of Expander Paks.



Figure 8. Connecting Expander Paks to Solar Stik power management

## Alternative Methods of Recharging the Expander Pak

Alternative methods of recharging should be performed using only regulated charging sources appropriate for 24 VDC LiFePO<sub>4</sub> batteries such as the 24VDC Li Battery Maintainer shown in Figure 9.



Figure 9. 24VDC Li Battery Maintainer with Inter-Connect Plug

### Recharging Voltage

**Do not connect an external charging source that exceeds 29.8 volts to the post terminals.** This may damage the battery and is not covered under any warranty.

### Correct Polarity

**Always connect to DC terminals using correct polarity.** Failure to connect using correct polarity will trip the master breaker or trigger protection circuits to engage.

## MAINTENANCE INSTRUCTIONS

### Expander Pak Storage

There is a simple rule to remember about maintaining the Expander batteries:

***Never store an Expander Pak in a discharged state! Charge the Expander Pak fully before placing it in storage.***

Other than keeping the battery fully charged during storage, an  $\text{LiFePO}_4$ -type of battery does not require any type of maintenance by the operator.

The Expander Pak has a relatively low self-discharge rate at 77 °F (25 °C) and can be stored for up to one (1) year at this temperature before it needs to be recharged. **However, the self-discharge rate increases as the storage temperature increases.** See [In-storage Preventive Maintenance Checks and Services](#) for complete specific charging instructions for a particular Expander Pak battery chemistry.

**Note:** If the Expander Pak is stored at temperatures above 91 °F (33 °C), then the time between maintenance checks and / or charges must be reduced to three (3) months.

#### In-Storage Charging Procedures:

Charge one—charge all. It is important to maintain an equal level of health between all Expander Paks in a System. If one (1) Expander Pak in a System needs to be charged during storage, it is likely that any/all others will also need to be charged. Charging all of the Expander Paks until they are charged fully will maintain balance and equality among them.

### CAUTION

Do NOT leave Li Expander Paks on a constant charge during long periods of storage. Cell damage may occur. Once the battery reaches 100% SOC during maintenance charging, the charging source should be removed until the next charging interval is determined.

Do NOT use a BMS reader to determine Li Expander Pak SOC during periods of storage. The BMS' reported values for SOC are not calculated using "cell self-discharge" information, which occurs in all batteries. The SOC may be reported at 100% even though the cells may only be at 50%.

# In-storage Preventive Maintenance Checks and Services

Failure to follow these instructions may result in permanent equipment failure and/or personal injury.

## Required Tools

Solar Stik PRO-Verter or [LiFePO<sub>4</sub> battery maintenance charger](#).

Table 1. In-storage Preventive Maintenance Checks and Services

Item #	Item to be Inspected	Interval* at 91-140 °F (33-60 °C) Storage Temp	Interval* at 77-90 °F (≤ 25-32 °C) Storage Temp	Procedures	Non-mission Capable
1	Visual inspection of 24VDC Li Expander Pak 1300	M <sup>1</sup>	Q <sup>2</sup>	<ol style="list-style-type: none"> <li>Inspect case for visible damage and missing items.</li> <li>Clean excessive dust or dirt accumulation from the exterior and ports.</li> <li>Close all unused port covers.</li> </ol>	~If the case is broken or split or if the port is damaged, contact Solar Stik Technical Support.
2	In-storage maintenance charging	Q <sup>2</sup>	S <sup>3</sup>	Charge Li Expander Paks for 24 hours using a PRO-Verter. If any other charging device is used, it must be rated for the Expander Pak storage capacity, voltage, and current limit.	If an Li Expander Pak has does not hold a charge after 48 hours of charging, contact Solar Stik Technical Support.

<sup>1</sup>Monthly (M)—every month

<sup>2</sup>Quarterly (Q)—every three months

<sup>3</sup>Semiannually (S) – every 6 months

# Li Expander Pak Transport

## Air

The following information is a summary of the conditions that apply to the 24VDC Li Expander Pak 1300 for air transport:

- **Dangerous Goods Training.** The international and U.S. transportation regulations require personnel involved in shipping the 24VDC Li Expander Pak 1300 to complete the appropriate level of HAZMAT training.
- **Classification.** The 24VDC Li Expander Pak 1300 is classified as Class 9 hazardous material.
- **Testing.** The  $\text{LiFePO}_4$  cells of the Li Expander Pak 1300 and the battery itself have passed UN 38.3 T1 – T8 tests.
- **Short Circuit Protection.** The 24VDC Li Expander Pak 1300 is protected against short circuit and unintended movement.
- **Accidental Activation.** The 24VDC Li Expander Pak 1300 is protected against accidental activation.
- **Net Weight Limit.** The net weight of the lithium batteries in the 24VDC Li Expander Pak 1300 is 17.3 kg and is below the maximum of 35 kg net weight limit.
- **Marking and Labeling.** The 24VDC Li Expander Pak 1300 must bear the following labels: Class 9 hazard and Cargo Aircraft Only labels. Packages must also be marked with Proper Shipping Name (UN3480 Lithium Ion Batteries) and Shipper and Consignee addresses.
- **Shipper's Declaration for Dangerous Goods.** A Shipper's Declaration for Dangerous Goods must be filled out and accompany the 24VDC Li Expander Pak 1300 for air transport. The certifying official must have the requisite training.
- **Master Air Waybill.** The Master Air Waybill or Bill of Lading (BOL) is the document that describes the shipment.

## Ground

The following information is a summary of the conditions that apply to the 24VDC Li Expander Pak 1300 for ground transport:

- **Dangerous Goods Training.** The international and U.S. transportation regulations require personnel involved in shipping the 24VDC Li Expander Pak 1300 to complete the appropriate level of HAZMAT training.
- **Classification.** The 24VDC Li Expander Pak 1300 is classified as Class 9 hazardous material.
- **Testing.** The  $\text{LiFePO}_4$  cells of the Li Expander Pak 1300 and the battery itself have passed UN 38.3 T1 – T8 tests.
- **Short Circuit Protection.** The 24VDC Li Expander Pak 1300 is protected against short circuit and unintended movement.
- **Accidental Activation.** The 24VDC Li Expander Pak 1300 is protected against accidental activation.
- **Net Weight Limit.** The 17.3 kg net weight of lithium batteries in the 24VDC Li Expander Pak 1300 meets the maximum of 35 kg net weight limit.
- **Marking and Labeling.** The 24VDC Li Expander Pak 1300 must bear the following labels: Class 9 Hazard label, Cargo Aircraft Only label. Packages must also be marked with Proper Shipping Name (UN3480 Lithium Ion Batteries Contained in Equipment) and Shipper and Consignee addresses.
- **Shipper's Declaration for Dangerous Goods.** Not required, but may be requested by your shipper.

## Disposal – LiFePO<sub>4</sub> Battery

As a general rule, lithium-ion batteries are managed as universal waste under the Resource Conservation and Recovery Act. However, battery disposal regulations vary on national, state/provincial, and installation levels. Disposal must be conducted in accordance with all applicable regulations. ANY breached or leaking battery is managed as hazardous waste.

Before initiating the disposal process for the Li Expander Pak, it must be fully discharged. Consult the local Hazardous Waste Storage Area (HWSA), Defense Reutilization and Marketing Office (DRMO), or other local authorities for the standard operating procedure for packaging, quantity, labeling, shipping, and tracking requirements. If an HWSA or DRMO is not available or does not accept the Li Expander Pak, contact the servicing environmental compliance organization. Solar Stik is also able to handle disposal of the Li Expander Pak at a cost to the customer. Solar Stik can be contacted at 800-793-4364.

The Li Expander Pak contains recyclable materials, and recycling is encouraged over disposal if a lithium battery recycling facility is available.

The box in which the replacement battery was shipped is UN rated and should be used to ship the defective battery to the appropriate disposal location.

# Technical Specifications

General	
Battery Chemistry	24 VDC Lithium iron phosphate
Nominal Operating Voltage Range	24 VDC to 28.8 VDC
Capacity*	1.38 kWh (54 Ah)
Max Discharge*	25 A continuous, 15-minute pulse at 50 A
Cycle Life*	> 2000 (80% depth of discharge)
Transport Case / Exterior Housing	Hard plastic; overmolded shock-absorbing corners
Transportation	<ul style="list-style-type: none"> <li>Class 9 Hazmat</li> <li>UN3480, lithium-ion battery</li> <li>Forbidden from transport on passenger aircraft</li> </ul>
Certification(s)	<ul style="list-style-type: none"> <li>IP67 (intrusion protection)</li> <li>UN 38.3</li> <li>Passed UNDOT38.3 T.3 Vibration and T.4 Shock</li> </ul>
Warranty	1-year materials and workmanship

\*@ 77 °F (25 °C)

Safety	
Fuse(s)	200 A nonreplaceable (overcurrent in charging direction)

Battery Management System Protection	
Overvoltage Limit	3.75 V per cell
Undervoltage Limit	2.50 V per cell
Overdischarge Current Limit	36–48 A, 16ms
Overtemperature Limit	<ul style="list-style-type: none"> <li>Any supercell 158 ± 9 °F (70 ± 5 °C)</li> <li>Relay heat sink 212 ± 9 °F (100 ± 5 °C)</li> </ul>
Low-temperature Charging	<ul style="list-style-type: none"> <li>Trip -13 °F (-25 °C)</li> <li>Reset 23 °F (-5 °C)</li> </ul>
High-temperature Charging	<ul style="list-style-type: none"> <li>Trip 131 °F (55 °C)</li> <li>Reset 122 °F (50 °C)</li> </ul>
High-temperature Discharging	<ul style="list-style-type: none"> <li>Trip 194 °F (90 °C)</li> <li>Reset 131 °F (55 °C)</li> </ul>

Connections	
Input(s)/Output(s)	24 VDC Inter-Connect**

\*\*Deltran 224-0061-BK

Environmental	
Operating Temperature***	<ul style="list-style-type: none"> <li>-26 °F to 149 °F (-32 °C to 65 °C, discharging)</li> <li>-4 °F to 122 °F (-20 °C to 50 °C, charging)</li> </ul>
Storage Temperature****	-4 °F to 122 °F (-20 °C to 50 °C)

\*\*\* Operating outside of range will accelerate the battery aging process

\*\*\*\* Prolonged exposure to high temperatures in storage will reduce battery life

Weights and Dimensions (L x W x H)	
Weight	34 lb (15.42 kg)
Dimensions	17.55 x 17.25 x 4.06 in (44.58 x 43.82 x 10.31 cm)

## Accessories



**24VDC Li Battery Maintainer  
120/230  
P/N: 14-1001000**



**24VDC Inter-Connect Cable  
Linear 5'  
P/N: 13-1000267  
(available in custom lengths)**



**24VDC Inter-Connect Cable 5'  
P/N: 13-0000032  
(available in custom lengths)**



**24VDC Inter-Connect Strip 7  
P/N 13-1000160**

# ADDENDUM – Understanding Li Expander Paks

## LiFePO<sub>4</sub> Batteries and the Battery Management System (BMS)

This section provides information about the individual battery cells that are integrated into Solar Stik Li Expander Paks and the multi-functional BMS that maintains them. Additionally, safeguards to prevent failure are discussed.

### LiFePO<sub>4</sub> Battery Chemistry

The Solar Stik 24VDC Li Expander Pak 1300 contains a custom LiFePO<sub>4</sub> battery module that was designed, tested, and UN certified for use in the Solar Stik System.

There are significant advantages to using LiFePO<sub>4</sub> batteries in that they offer good electrochemical performance with low internal resistance. Key benefits include high current rating and long cycle life, good thermal stability, enhanced safety and good tolerance for stressful operating conditions:

- High cycle life; up to 3000 cycles\*
- Rapid and deep discharges (can go to near 0% without hurting the cells\*)
- Rapid recharge
- High energy density—twice that of lead-acid (double the energy for its weight)
- Safety: LiFePO<sub>4</sub> battery chemistry is as safe as lead-acid
- Other than passenger aircraft, transport regulations are the same as for lead-acid

\* The cycle life of LiFePO<sub>4</sub> is generally advertised as 3000 cycles, but it may be affected by adverse operating temperature conditions (extreme heat and cold) and high C-rates (rate of current charge and discharge)

**\*Batteries must not be stored in a discharged state or they may become permanently damaged.**

**The primary factors that determine the life-expectancy of a battery are:**

- Cycles and Application
- Abuse and Improper Cycling

Either one of these forms of abuse alone could cause damage while the battery is not in service. A combination of these abuses will (most likely) cause damage while the battery is not in service. The duration of exposure to high heat will be directly correlated to the amount of damage done. These phenomena are not unique to LiFePO<sub>4</sub> batteries.

Storing Li Expander Paks in a hot container is unavoidable at times; however, the damage can be mitigated in two ways:

1. ALWAYS charge the Expander Paks fully before storage.
2. Perform a maintenance charge on the system at three (3) months. The maximum time between services (FULL recharging) for a system stored in a climate-controlled environment is six (6) months. If it is stored in a high-heat environment, then more frequent inspection/charging is absolutely necessary.



Unlike lead-acid batteries, the VOLTAGE OF A  $\text{LiFePO}_4$  CELL IS NOT AN INDICATION OF THE BATTERY'S SOC during cycling. Voltage can, however, be used to determine a battery's SOC at fully-charged and fully-discharged states.

This is a very important factor in understanding how to diagnose and maintain these batteries properly.  $\text{LiFePO}_4$  chemistry batteries maintain high voltages up to the point that they are fully charged or discharged, at which point the voltage will rise or drop rapidly. This makes it difficult to use the battery's voltage to determine the actual SOC. This is precisely why regimented maintenance charging is vital.

## Battery Management

A BMS ensures that individual battery cells are charged/discharged and maintained optimally. In a working configuration, lithium batteries usually require unique charging times, voltages, and amperages, and they can be easily and permanently damaged if they are not used with a proper BMS. Cell damage can range from significantly shortened life to general poor performance, and in extreme cases a damaged cell can overheat, causing an explosion or fire. The role of the BMS is simple: It controls the actual operating conditions of each cell, so that they do not exceed safety limits or cause damage to the cells.

## Cells and BMS Overview

Lithium batteries operate in a much more confined spectrum of voltage and current than lead-acid batteries. Under/overvoltage conditions are tightly regulated by an internal protection circuit. However, just as with lead-acid batteries, irreversible damage can occur to a lithium cell when it is discharged below a certain voltage (Li Expander Pak is 2.5 V/cell) for an extended period of time.

Solar Stik Li Expander Paks contain eight (8)  $\text{LiFePO}_4$  “supercells”. These cells require a complex BMS, which manages the supercells and their protection circuits. The BMS is solely responsible for enabling or disabling the battery “terminals” where any external circuit is connected (i.e., load, Expander Pak, solar charging source, etc.) and through which all current flows in and out. Each supercell has a cell-balancing device to make sure all of the cells in a battery are charged evenly and are synchronized with the other cells as they charge and discharge.

**Note:** Eight (8) supercells wired in series that are each at 2.5 V means that the battery voltage is 20 V, which is the terminal disconnect voltage, or low SOC threshold. If the eight (8) supercells are all at 2.9 V, then the battery voltage will be 23.2 V (terminal connection voltage). For the purposes of this discussion, we will be referring to the individual cell voltage because one cell alone at 2.5 V can cause the entire battery module to stop working.

All Solar Stik Li Expander Pak batteries have a BMS that consists of protection and cell maintenance circuits:

- The protection circuit monitors the cell voltages, temperatures, and current going through the battery. It also controls the input/output of the battery; when all of the conditions are good, current can flow in/out of the battery terminals. If the temperature, voltage, or current are outside of their preset limits, then the battery terminals are disabled and no current can flow in/out.

- The cell maintenance circuit manages the cell voltages, and actively balances voltages across the cells as the battery cycles. It calculates for parity across all eight (8) Super Cells, ensuring long operational life.

**The Li Expander Pak 2400 offers a BATTERY STATUS LED located on the outside of the Expander Pak case.**

The BATTERY STATUS LED circuit monitors and reports the output of the battery. If the STATUS LED controller senses the output has been disabled for any reason, it turns the LED to red. BATTERY STATUS LED is not connected to the BMS-computed SOC; it is only monitoring the output of the battery and indicating to the user if the terminals of the battery are active or not.

**The Li Expander Pak 1300 battery BMS has only one control board for protection and cell management. There is no display or STATUS LED on the case.**

Without the BMS protection circuit, there would be a significant safety risk. For example, if charging voltage and current are applied to a battery with dead or damaged lithium cells and no BMS, the remaining (functioning) cells would be exposed to higher individual voltages in order to compensate for the loss of dead cells in the battery. The external charging circuits would attempt to function by keeping the battery at its prescribed operating voltage, completely unaware that individual cells in the battery were being overcharged. With a BMS installed, however, the failure of a cell will trigger the protection circuit; thus the battery will protect itself and the operator.

Charging mechanisms used with ANY Li Expander Pak do not have the ability to recognize when a cell in a battery module has failed or, by extension, when a battery has removed itself from service. In any lithium battery that is made of multiple cells, that is the exclusive role of the BMS. External charging sources such as solar, vehicular, and the AC circuit will continue to attempt to charge at their set charging voltage values (in this case, at about 28 V) regardless of an individual cell's health or SOC. If one battery drops out of service, the system voltage is not affected, and the loss of one battery will have minimal impact on the overall system performance. If this situation is amplified, and multiple Expander Paks are removed from the system, then the system's performance will progressively degrade.

#### **Additional Notes about BMS operation:**

- The BMS is the key feature enabling the battery to handle high charge and discharge rates (up to 35 A each) and also allows multiple batteries to be used in concert (in a scaled configuration).
- In order for a scaled battery bank (multiple Li Expander Paks in a parallel connection) to function properly, the individual battery BMSs must be synchronized with each other. This is accomplished by fully cycling the bank 2–3 times after the batteries are connected.

#### **Li Expander Pak in an Overdischarged State**

It takes only ONE (1) supercell reaching a voltage of 2.5 VDC in an Li Expander Pak to cause an overdischarged condition. If the BMS senses that one cell has breached this low-voltage threshold, the protection circuit will immediately deactivate the battery terminals. This is also considered 0% SOC for the whole battery. This will protect the cell from going into a deeply discharged state, which can cause damage to the individual cell.

If the BMS has disconnected the battery terminals from service due to low SOC, it will continuously scan the terminals to see when charging voltage is being applied so it can reconnect the battery into service. This “sense” circuit is very active when the battery is first disconnected at the terminals due to low SOC. If the discharged condition persists and the cells are not recharged in a timely fashion, the cell voltages continue to deteriorate.

### **Self-recovery from an Overdischarged State**

It is possible for a battery to self-recover from an overdischarged condition.

If the battery is discharged slowly (low current) to the point at which the protection circuits engage, there is only a minimal chance cells can reconnect on their own.

However, if the battery cells are discharged at a high rate, the chemical reaction inside the cells will often struggle to “keep up” with the demand, therefore, the voltage will drop and the protection circuit will disconnect the cells from service.

When cells are allowed to rest from a rapid discharge, the cells will continue to chemically react, causing voltage in the cells to rise. When the cell voltage recovers back above 2.9 V, the protection circuit will enable the output of the battery.

If either of these conditions occur, the battery should immediately be put into charge mode.

### **BMS Operation in an Overdischarged State**

LiFePO<sub>4</sub> battery cells, as discussed earlier, will drop in voltage very quickly when they have reached low SOC. The BMS will disconnect the terminals to prevent further discharge by an external component, but the BMS itself requires power to operate. THE BMS WILL CONTINUE TO USE POWER FROM THE CELLS TO PERFORM ITS PRIMARY FUNCTIONS, even if the battery has disconnected itself from service. The cells will continue to discharge internally in support of the BMS functions, and the voltage can fall very rapidly to the point of non-recovery. If the battery protection circuit is engaged due to low SOC, there is precious little energy left in the battery, so timely recharging is extremely important.

As time passes and the cells continue to lose voltage, the BMS will slow down its functions to preserve as much energy in the cells as is possible. One of these functions is to search for charging voltage at the battery terminals. Once the battery terminals are disconnected from service, the BMS uses a sense circuit to pulse the terminals, sensing for voltage. When the presence of higher voltage (greater than 23.2 V) is sensed at the terminals, it will begin allowing charging current into the cells.

The longer the battery has been in the discharged state, the greater the interval between the pulses; thus, the longer the charge voltage must be applied in order for the BMS to sense the voltage. In extreme cases where the cells have remained at the overdischarged state for an extended period, the BMS will pulse the terminals only sporadically; therefore, the Li Expander Pak may need to remain connected to a charging source for multiple days in order for the BMS to allow enough power back in through the terminals to effect a recovery.

## **Self-Discharge**

LiFePO<sub>4</sub> has a higher self-discharge than other Li-ion batteries, which is exacerbated in high temperatures.

## **Bricking a LiFePO<sub>4</sub> Battery**

As soon as the BMS senses the cell voltage is too low to discharge further, time is of the essence to place the batteries on charge. Failure to do this may cause a fatal error known as “bricking”.

Once the batteries reach their internal disconnect voltage, the voltage can fall very rapidly in the internal cells, causing the battery to brick. This means that the battery cells are non-recoverable, and the battery module must be replaced. (See LiFePO<sub>4</sub> Battery Disposal)

## ABOUT SOLAR STIK, INC.



SOLAR STIK®

### Mission Statement

Using American-made components and constant innovation, Solar Stik creates portable power solutions that enable self-sufficiency for the soldier, the sailor, and beyond. In doing so, we save lives, change lives, and help revive American manufacturing.

### STIKopedia

[STIKopedia](#) is a compilation of everything you would ever want to know about portable Hybrid Power Systems, including the philosophy and mechanics of high-efficiency circuits, and the individual technologies used to create them.

### Solar Stik Training and Education

- **Solar School (St. Augustine, FL)** provides an introduction to the design and support of small-scale, renewable-energy, power generation systems, with detailed explanation of system components. Advanced configuration options with hands-on deployment of actual systems will enhance student understanding.
- **Solar Stik New Equipment Training (on site)** teaches Hybrid System configuration options with hands-on deployment of actual systems to enhance student understanding.

Solar Stik Training Courses are tailored to the specific needs of the students. To schedule Solar Stik Training or to learn more about the curriculum, please contact us.

### Contact

#### Technical Support Line

800-793-4364 Ext. 102

(24 hours a day, 365 days a year)

#### Address

Solar Stik, Inc.

226 West King Street

Saint Augustine, Florida 32084

#### Website

[www.solarstik.com](http://www.solarstik.com)

Trademarks and Logos are the property of Solar Stik, Inc. unless otherwise noted.

This manual is subject to revisions without prior notice.

Copyright 2021 Solar Stik, Inc.

All Rights Reserved.